



Art.68012

Art.68113

Art. 68012 Portable, high-pressure hand-operated grease pump.

- Equipped with 13 kg portable tank
- grease follower plate
- delivery hose 2.5 m complete with terminal rigid with 4-jaw clamp (art. 66740)

N° 1 packing m^3 0,070 kg 10,4

Art. 68113 Pedal-operated grease pump, high pressure, wheel-mounted.

- Equipped with 13 kg wheel-mounted tank
- grease follower plate
- delivery hose 2.5 m complete with terminal rigid with 4-jaw clamp (art. 66740)

N° 1 packing m^3 0,100 kg 14

Article	68012	68113
Max. capacity tank	13 kg	13 kg
Length delivery hose	2,5 m	2,5 m
Pressure of grease in delivery	140/150 bar	190/200 bar
Capacity every 10 cycles of lever	60 g	40 g

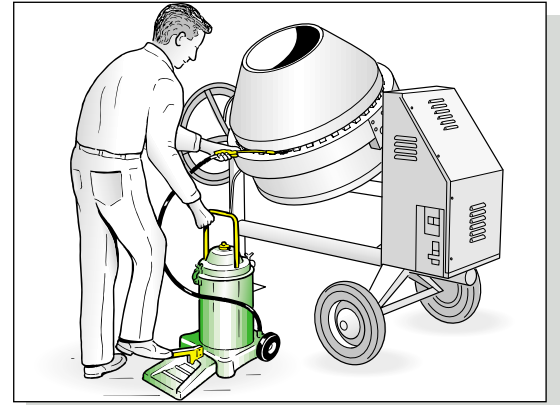
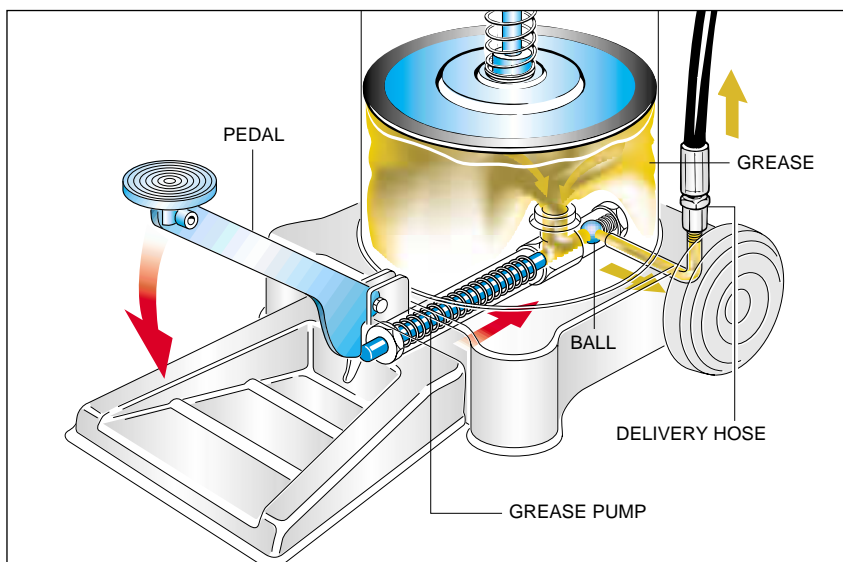

Pedal and hand-operated portable grease pumps. For practical and safe greasing anywhere, and on any motor vehicle and/or machinery.

The **seamless pressed tank** guarantees the follower plate supplied maximum adherence and functionality.

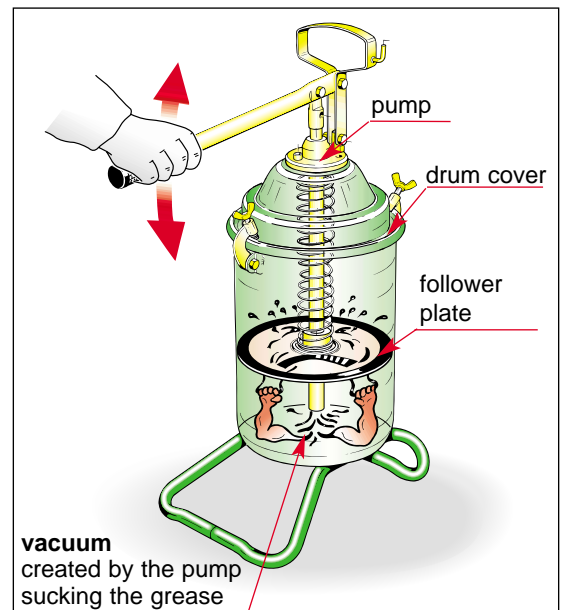

The follower plate, indispensable when using particularly hard greases, is drawn towards the bottom of the drum by the vacuum created by the pump in grease suction stage.

Overall dimensions

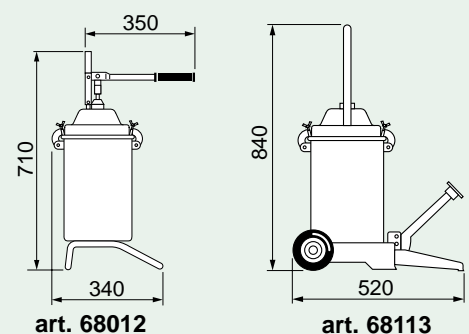



Handy and functional handle for carrying and handling.

Rigid grease terminal with tap.

Hose of 2.5 metres 1/8"G

Pedal operating a single pump efficient enough for high-pressure greasing.

The seamless steel tank guarantees maximum functionality and adherence to follower plate

Two fixed wheels assembled on a stable and sturdy platform.

