





PANTOGRAPH Series 115/14 lt

Art. 46115 **115lt**Art. 46116 **115lt**



Art. 46114 **Universal** pantograph oil **drainer** for cars, with wheel-mounted **115-litre** tank equipped with level-gauge, without suction group and probes

 N° 3 packing m^3 0,360  kg 49,5

Art. 46115 **Universal** pantograph oil **suction/drainer** for cars, with wheel-mounted **115-litre** tank equipped with level-gauge, supplied with series of probes art. 45560 (See page 122)

 N° 4 packing m^3 0,420  kg 50,8

Art. 46116 **Universal** pantograph oil **suction/drainer** for cars with bowl, with wheel-mounted **115-litre** tank equipped with level-gauge, supplied with series of probes art. 45560 (See page 122)

 N° 4 packing m^3 0,420  kg 53,2

Article	46114	46115	46116
Tank capacity	115 lt	115 lt	115 lt
Max. draining capacity	97 lt	97 lt	97 lt
Chamber capacity	/	/	8 lt
Bowl capacity	14 lt	14 lt	14 lt
Depressurizing pressure	/	7 bar	7 bar
Depressurization time	/	3-3,5 min	3-3,5 min
Noise level	/	75 dB	75 dB
Suction speed with oil at 70-80°C, probes 6 mm.	/	1,5-2 lt/min	1,5-2 lt/min
Total suction capacity	/	85-90 lt	85-90 lt
Suction/draining hose	2 m	2 m	2 m
Max. discharge pressure	0,5 bar	0,5 bar	0,5 bar

Important: DO NOT drain brake fluids, fuels or flammable liquids of any kind, corrosive liquids.

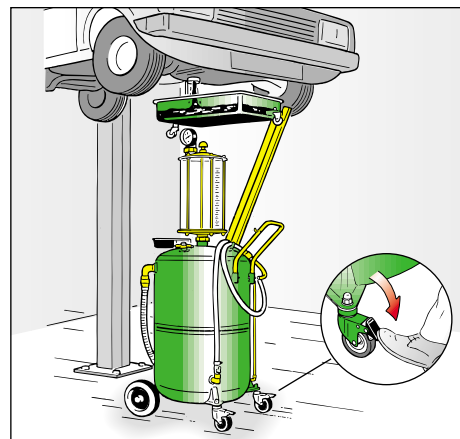

Due to their versatility, these **pantograph oil suction/drainers** are **universal** drainers because they can be used to change the oil of all motor vehicles:

- **by gravity** with tank on floor
- **by gravity** with tank raised, with motor vehicles placed on auto lift or pit.
- **by suction** with probe inserted directly in the engine, and anywhere because they do not require continuous connection to the compressed-air line or to other energy sources.

(The oil must be hot 70/80° C).

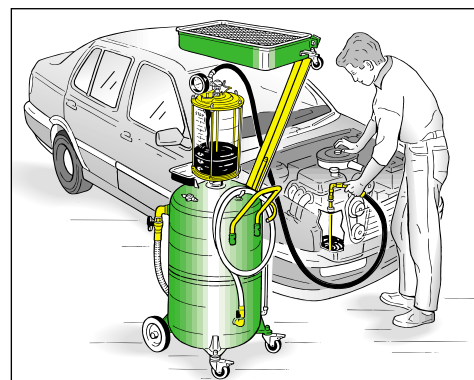

The transparent chamber allows the quantity and quality of the sucked oil to be controlled immediately.

Overall dimensions

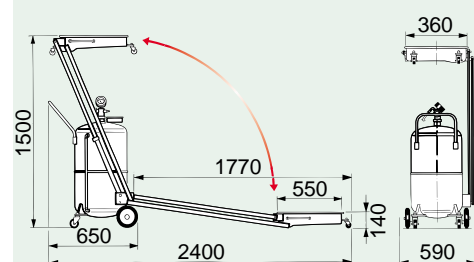

art. 46114-46115-46116

