

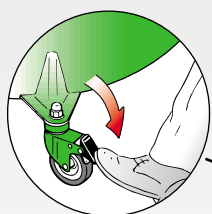



PANTOGRAPH Series 115/50 lt



Wheel with brake

Art. 46215 **115lt**

Art. 46215 **Universal** pantograph waste oil **suction/drainer** for trucks, with wheel-mounted **115-litre** tank equipped with level-gauge and removable tool tray, supplied with series of probes art. 45560 (See page 122)

 N° 4 packing m^3 0,520  kg 68,7

Article	46215
Tank capacity	115 lt
Max. draining capacity	97 lt
Bowl capacity	50 lt
Depressurizing pressure	7 bar
Depressurization time	3-3,5 min
Noise level	75 dB
Suction speed with oil at 70-80°C, probes 6 mm.	1,5-2 lt/min
Total suction capacity	85-90 lt
Suction hose	2 m
Draining hose	2 m
Max. discharge pressure	0,5 bar

Important: DO NOT drain brake fluids, fuels or flammable liquids of any kind, corrosive liquids.

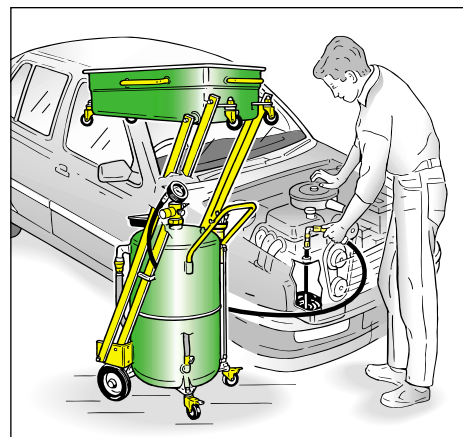

Due to their versatility, the **pantograph oil suction/drainers** are **universal** drainers because they can be used to change the oil of all trucks:

- **by gravity** with tank on floor
- **by gravity** with tank raised, with motor vehicles placed on auto lift or pit.
- **by suction** with probe inserted directly in the engine, and anywhere because they do not require continuous connection to the compressed-air line or to other energy sources (the oil must be hot 70/80° C).

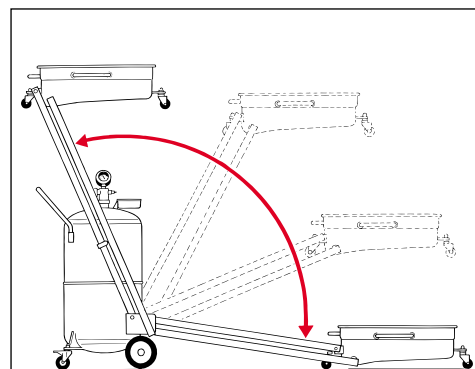

The pantograph arms allow the tank to be placed on the floor or raised, for draining under a lift.

